

# Worktops

Processing guidelines

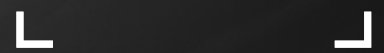

For you to create



Fundermax

## Content

<b>3</b>	<b>WORKTOPS</b>
<b>4</b>	<b>PROPERTIES</b>
<b>5</b>	<b>GUIDELINES FOR HANDLING MAX COMPACT WORKTOPS</b>
<b>8</b>	<b>PROCESSING GUIDELINES FOR KITCHEN WORKTOPS</b>
8	Construction information
10	Mechanical fastening
12	Glued fastening
14	Sink and glass top stove installation
16	Installation of niche rear panel
<b>18</b>	<b>THE PROCESSING OF MAX COMPACT WORKTOPS</b>
18	Safety measures
19	General processing guidelines
20	Cutting
21	Cutting with handheld tools
22	Milling machines – edge processing
24	Joining
25	Routers
26	CNC processing
27	Edges and grooves
27	Inner notches and cut-outs
28	Drilling
30	Basics
31	Bonded edge joints
32	Glueing
<b>34</b>	<b>CLEANING RECOMMENDATIONS</b>



## Worktops

Due to their high scratch and abrasion resistance as well as high impact resistance and resistance to high temperatures, Max Compact panels are ideally suited for horizontal use as a worktop. Another advantage of these panels is the hygienically sealed, pore-free, closed surface made of melamine resin that is very easy to clean and is particularly resistant to many chemicals. Max Compact worktops are ideal for the installation of undercounter sinks and flush stovetops.

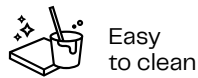

Fig. 1

MAX COMPACT PANEL WITH SAXUM SURFACE

Max Compact worktops are duromer high-pressure laminate panels (HPL) in accordance with EN 438 and are produced in laminate presses under great pressure and high temperature.

## Properties



Easy to clean



Impact resistant



Food grade



Heat resistant



Scratch resistant



Solvent resistant



Durable



Quick installation

### FORMAT

4,100 x 1,300

### PANEL THICKNESS

The optimal thickness for Max Compact panels for use as worktops is 12 mm.

Different panel thicknesses, fastening distances and the expected load capacity are all directly related and must be dimensioned accordingly.

### PROPERTIES\*:

- scratch resistant
- solvent resistant
- food grade
- heat resistant
- easy to clean
- hygienic
- impact resistant (EN ISO 178)
- decorative
- abrasion proof
- bending resistant (EN ISO 178)
- frost and heat resistant from -80°C to +80°C
- Temporarily heat resistant up to 160°C (EN 438)
- easy to install
- durable
- resistant to chemicals

## Guidelines for handling Max Compact worktops

### TRANSPORT AND HANDLING

Handle Max Compact worktops with care in order not to damage the edges and surfaces of the high-quality material. In spite of the excellent surface hardness and the installation protection film, the stack weight of Max Compact worktops is a possible cause of damage. Therefore, any form of dirt or dust between the panels must definitely be avoided.

Max Compact worktops must be secured against slippage during transport. When loading or unloading, the panels must be lifted. Do not push or pull them over the edge (see Fig. 2)

Transport protection films must always be removed from both sides at the same time.

Maybe there is a stronger adhesion of the foils on the surface because of the storage. Therefore there might be a higher effort to remove the foil. That does not have any effect to the quality of the product and does not result into a complaint. The transport protection film must not be exposed to heat or direct sunshine.

### STORAGE AND AIR CONDITIONING

Max Compact should always be left in the original packaging. The panels should be stacked horizontally on a flat, stable and padded raised surface. If this is not possible, the panels can be temporarily stored as shown in Fig. 4. The panels must lie completely flat. After removing the panels, the original packaging should be closed again.

Cover plates must always be left on the stack (see Fig. 3). The top cover should be weighted down. The same applies, in principle, for cut-panel stacks.

Incorrect storage can lead to permanent deformation of the panels.

Max Compact worktops should to be stored in closed rooms under normal climatic conditions, temperature about 15°C – 25°C and relative humidity at about 40% – 60%. Climate differences on the two surfaces of a panel are to be avoided.

With pre-installed fastening elements, therefore, care is to be taken that the climatic effect is uniform on all sides. Use intermediate layers of wood or plastic (see Fig. 5).



Fig. 2



Fig. 3

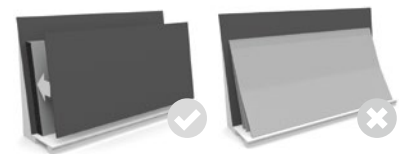
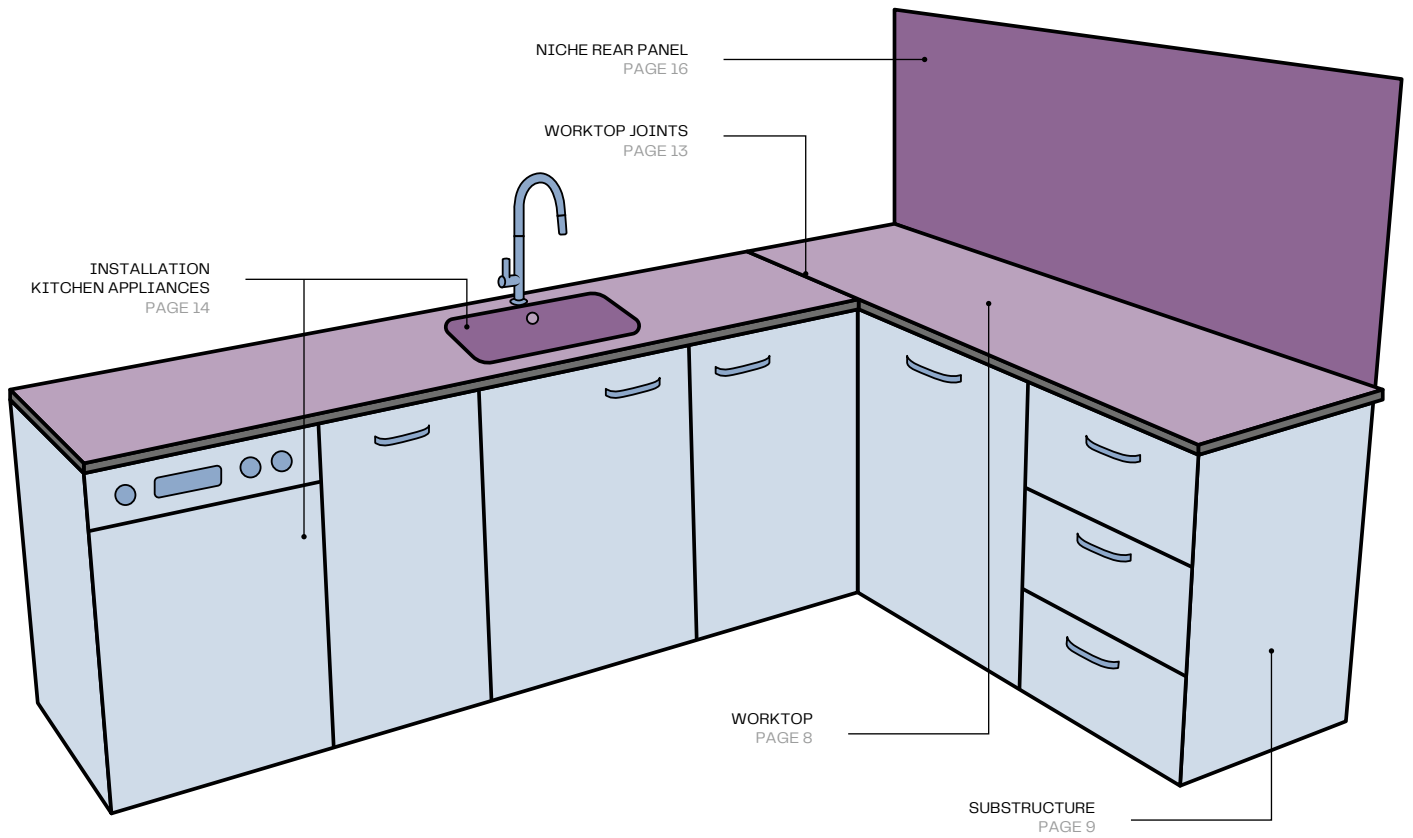

Fig. 4



Fig. 5





# Processing guidelines for kitchen worktops

## CONSTRUCTION INFORMATION

Max Compact worktops shrink when releasing moisture. Max Compact worktops expand when absorbing moisture. When working with and using the panels in construction, these possible dimensional changes must be taken into consideration.

The dimensions of Compact panels are influenced by changes in relative humidity. It is therefore essential to ensure there is sufficient expansion space when installing the panels. As a rule of thumb, calculate 2 mm of expansion space for each meter of panel.

- Due to the material characteristics, when connecting Max Compact worktops to one another (double, butt or miter), it is essential to ensure that all the parts to be connected are arranged in the same production direction. In other words, only connect horizontal with horizontal and vertical with vertical. Left over panel pieces should therefore always be marked with the production direction.
- It is not recommended to make corner joints and worktop joints exclusively by gluing; these joints should always be supported by mechanical connections.
- Recesses/outlets for the sink, glass top stove, sockets, etc., must always be made with an inner radius of 5 mm. Pointed corners are not recommended. Cutouts for sockets, worktop connectors, etc. can be ideally milled on site with a hand-held CNC milling machine (Shaper Origin).
- In general, it is important during construction and installation to ensure that the material is not subjected to accumulating moisture. The panel material must always be able to dry. It must be ensured that the rooms are adequately ventilated.
- Visible edges or edges in the handle area must be chamfered or at least broken with sandpaper to avoid injuries and material damage.
- For a perfect surface that is easy to clean, we recommend not milling the surface of Max Compact worktops.
- The countertop is characterized by high heat resistance. However, to protect the surface permanently, we recommend using a trivet—especially for hot pots and pans, as these can reach temperatures that exceed the material's load limit.
- To protect the surface in the long term, knives should never be used directly on it – please always use a cutting board. Direct contact with stoneware, cast iron pots, or similar objects should also be avoided, as these can cause scratches.
- Max Compact countertops with a colored core are only suitable to a limited extent in areas subject to heavy use due to the increased visibility of dirt.

## NOTICE:

We reserve the right to make changes that serve technical progress.

### SUBSTRUCTURE

When installing the Max Compact panel, sufficient ventilation on both sides of the panel must be ensured. Different temperatures or moisture levels in front of and behind the countertop can lead to warping of the panels. For this reason, the panels should be placed on a sufficiently stable substructure so that air circulation is guaranteed on the front and back of the panel. If the base cabinets are not strong enough, they must be reinforced with additional elements. The base cabinets and substructures should also be aligned. Any differences in height should be compensated, for example with a suitable spacer.

In order to properly “ventilate” the Max Compact worktops, it is necessary to design the kitchen base cabinets with an open top so that an air exchange can take place.



EXAMPLE OF MECHANICAL FASTENING

Fig. 6

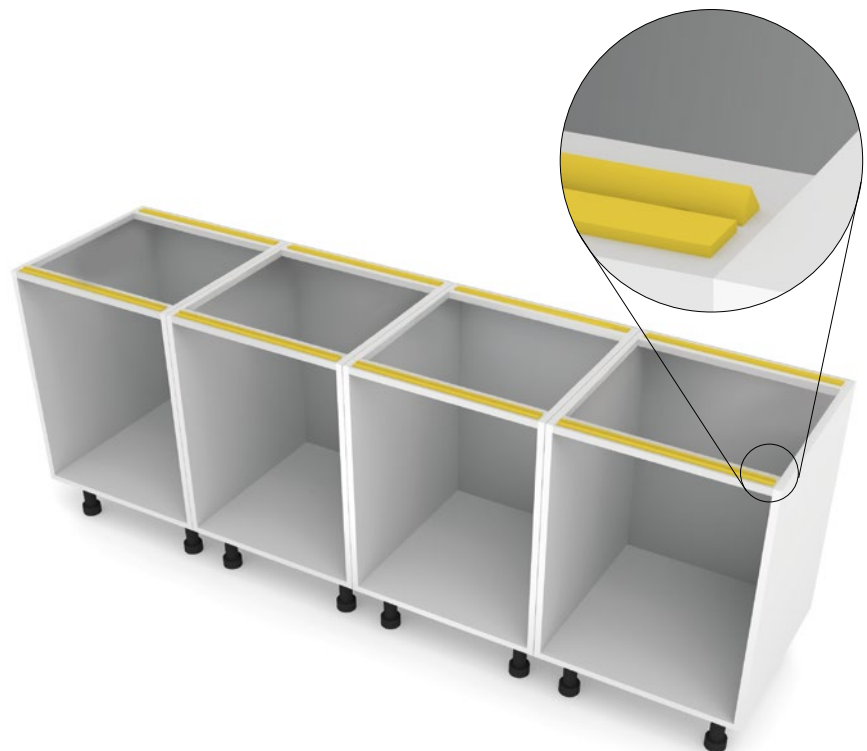

EXAMPLE OF GLUED FASTENING:

Fig. 7

## Mechanical fastening

Due to the material characteristics of Max Compact worktops, the fastening points must be designed as fixed and sliding points.

### Fixed Point:

The fixed point serves the uniform distribution (halving) of the swelling and shrinkage movements. The drill hole for the fixed point in the Max Compact panel should have the same diameter as the fastener. For each panel, a fixed point is placed as close as possible to the center of the panel element. All other fastening holes are designed as sliding points.

### Sliding Point:

Based on how much space is needed for expansion, the diameter of the drill hole in the substructure should be that much larger than the diameter of the fastening means. The screw head should always cover the drill hole. The fastening means is to be set such that the panel can move. The screws must not be too tight. The center of the hole in the substructure must match the center of the hole in the Max Compact panel. Drill with a centering aid!

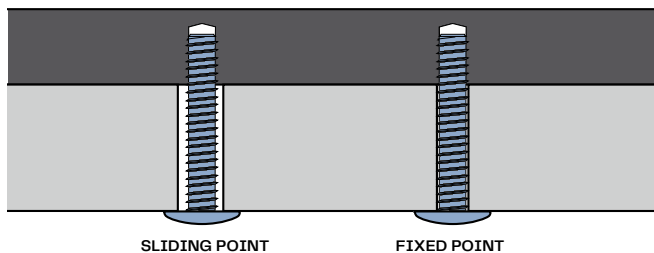

The panels should be fastened from the middle outwards. The Compact panels can be fastened in different ways, but due to the material characteristics it is always important to ensure that they are installed in a tension-free manner. The fastening can be done mechanically with screws from the bottom. The screws can either be screwed directly into the panel or screw-in sleeves with external and internal threads (e.g. sleeves from the company Rampa) can also be used.

Should the panels be fastened directly by screw or if a screw-in sleeve is used, it should be noted that the panel must be pre-drilled one thread smaller than the screw or sleeve and that a wall thickness of at least 2.0 mm is maintained after subtracting all tolerances. Suitable screws are those with a metric thread and a flat head. Do not use counter sunk screws. If necessary, use washers/rosettes.

Please observe our recommendations for drilling blind holes vertically and parallel to the panel surface in the chapter Drilling on page 28.

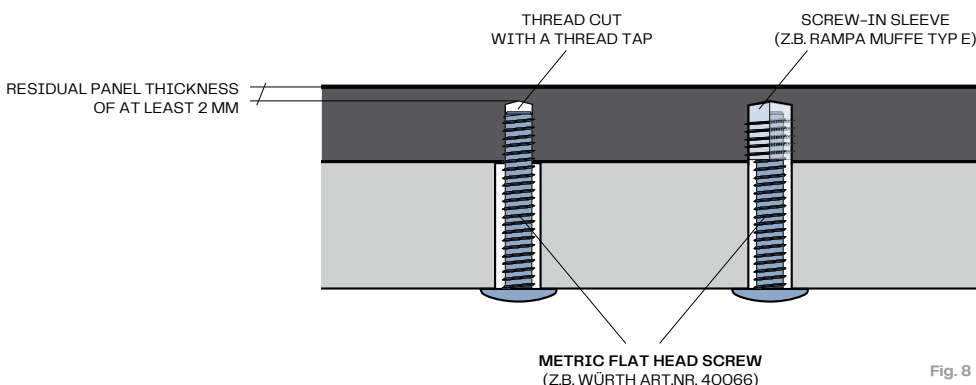

Fig. 8

## FASTENING DISTANCES FOR MECHANICAL FASTENING



Fig. 9

MAX COMPACT			
Thickness (mm)	Fastening distance (mm)	Edge distance (mm)	Free overhang (mm)
12	550	20-80	50

Table 1

For larger panel projections, we recommend the formation of a substructure for additional bracing and stabilization of the panel.

## Glued fastening

An alternative to the hidden, mechanical fastening is gluing the Max Compact worktops with especially suitable adhesive systems. Well known facade adhesive systems from companies such as Innotec, Sika and MBE are suitable.

To align the Max Compact worktops, we recommend that you only remove the cover film from the corner of the double-sided adhesive tape. This is because the weight of the panel can cause the double-sided adhesive tape to immediately adhere to its surface, making it difficult to move/align the panel.

Please observe the processing guidelines of the adhesive manufacturer.

It is always recommended to test the glue first under local conditions. When working with adhesives, solvents and hardeners, the safety regulations for occupational safety must be observed.

### FASTENING DISTANCES FOR GLUED FASTENING

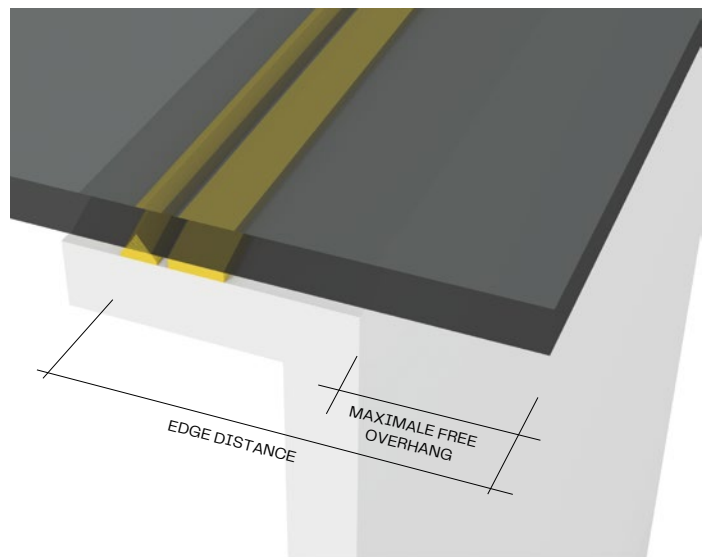

Fig. 10

MAX COMPACT			
Thickness (mm)	Fastening distance (mm)	Edge distance (mm)	Free overhang (mm)
12	300	20-80	50

Table 2

## Edge sealing

For a high-quality appearance, the edge can be treated with oil varnish (e.g., linseed oil varnish).

Max Compact worktops with a through-colored core are only suitable for use in areas subject to heavy wear due to the increased visibility of dirt.

For this reason, we recommend edge sealing in heavily frequented kitchen areas, such as around sinks and dishwashers. This can be done with a transparent lacquer, for example, to provide additional protection for the edge.

For larger panel projections, we recommend the formation of a substructure for additional bracing and stabilization of the panel.

## WORKTOP JOINTS

When making corner joints, it must be ensured that the kitchen base cabinets are aligned and any height differences should be compensated for using spacers. Worktop joints must be made using suitable connection means. Please note when using glue for worktop joints that a wall thickness of at least 3 mm is maintained after subtracting all tolerances.

Worktop connectors are ideal for connecting worktops. Connectors specially designed for thin worktops are available from Schachermayer (item no. 105030022) and Ziegelmüller (item no. 80900010) and are recommended. We recommend two worktop connectors for worktops up to 800 mm wide. For worktops wider than 800 mm, we recommend three worktop connectors.

Connecting elements such as lamellas or springs ensure that the butt joint is flush.

Please observe our recommendations for drilling blind holes vertically and parallel to the panel surface in the chapter Drilling on page 28.

### Important notice:

Using only glue for worktop joints is not recommended! Glued corner joints and worktop extensions should always be supported with mechanical connections.

When making worktop joints and connections to other furniture parts, walls, etc., please observe the necessary expansion space for a tension-free movement of the Max Compact worktops.

For worktop joints where the panels are not aligned in the same direction, we recommend a chamfer of approx. 1 mm for textured surfaces to ensure an attractive appearance.

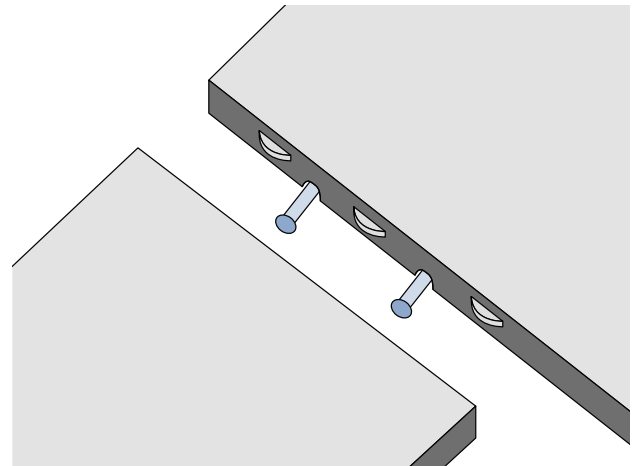

Fig. 11

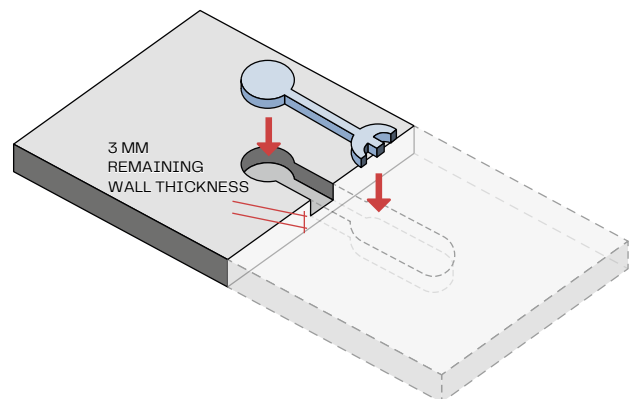

Fig. 12

## Sink and glass top stove installation

When installing glass top stoves and sinks, please observe the following:

- Due to the material characteristics of Max Compact panels, it must be ensured that there is sufficient expansion space when installing the panels. As a rule of thumb, calculate 2 mm of expansion space for each meter of panel.
- Recesses/outlets must always be made with an inner radius of at least 5 mm. Pointed corners are not recommended.
- Please ensure that all loads can be borne by the entire construction (e.g. with a full sink).
- When milling the Max Compact worktops, make sure that at least 50% of the panel thickness remains. For a 12 mm worktop made of Max Compact worktops, the milling depth should be no more than 6 mm. In the case of deeper milling, additional support of the worktop with a suitable substructure in this area is recommended.
- For a perfect surface that is easy to clean, we recommend not milling the surface of Max Compact worktops.

### INSTALLATION OF GLASS TOP STOVES

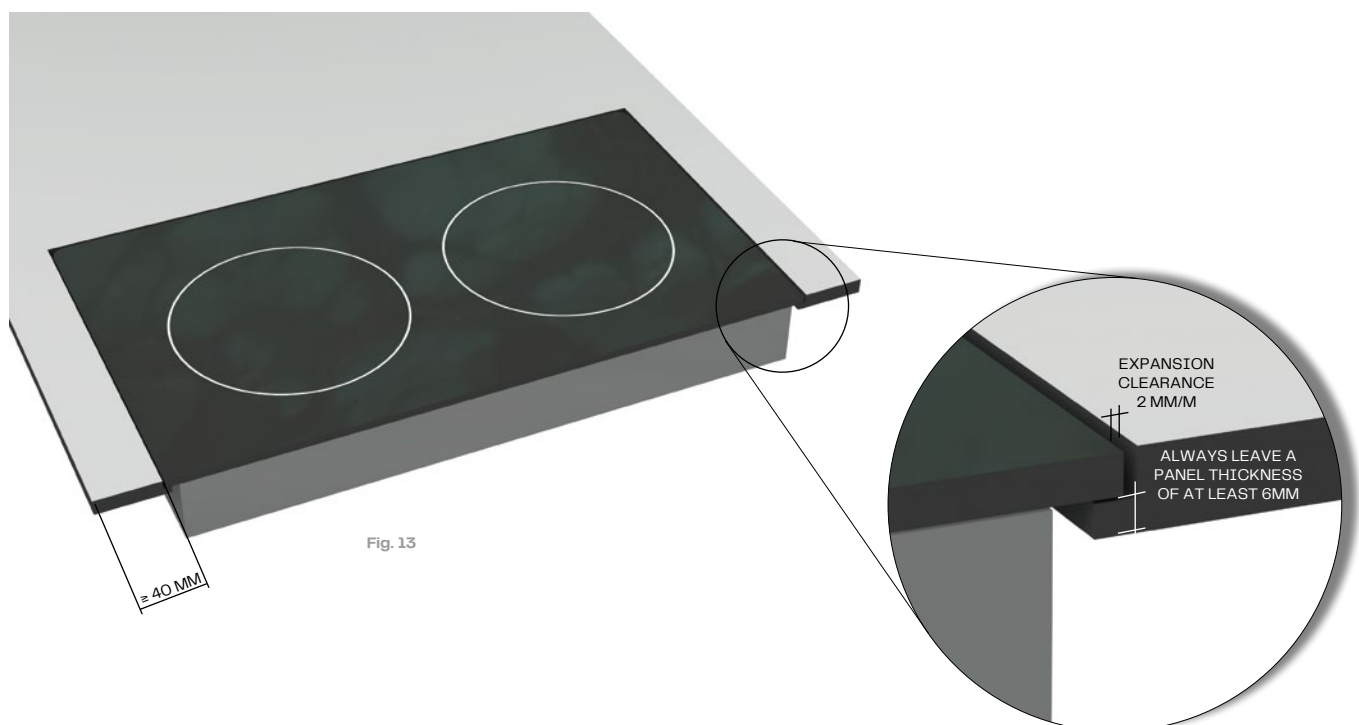

**INSTALLATION OF A RECESSED SINK**

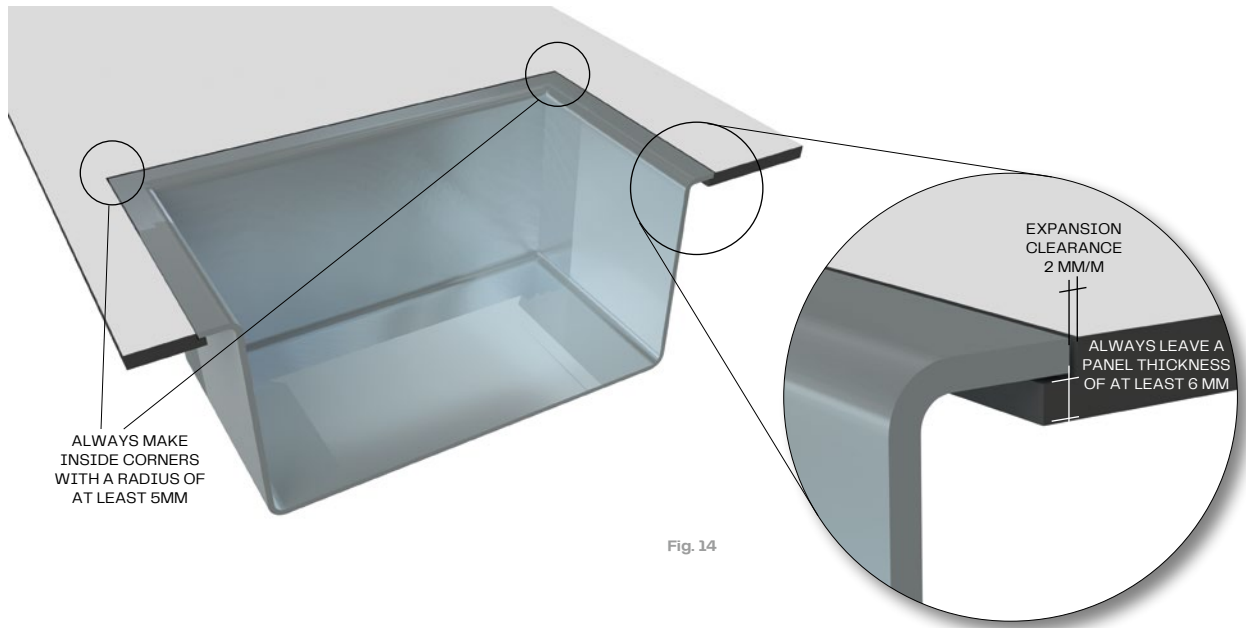

**INSTALLATION OF BOTTOM MOUNT SINKS**

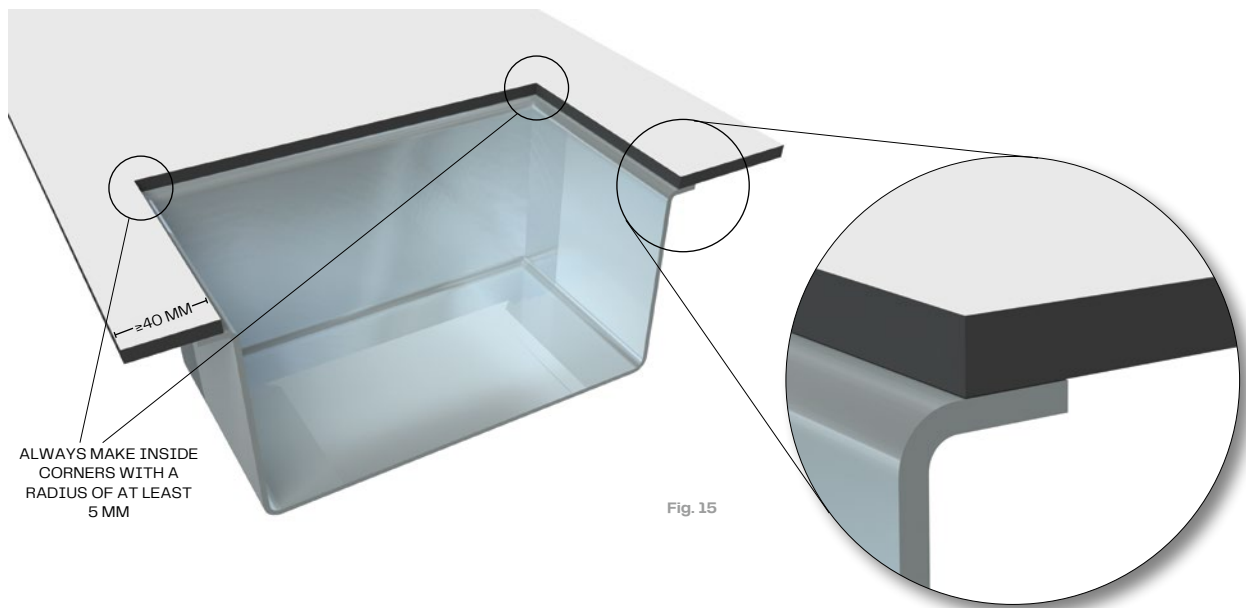

## Installing the niche rear panel

For the substructure, you can use Max Compact board strips or thin aluminum strips that are at least 3.0 mm thick. The strip-shaped substructure helps create the best surface for gluing.

If the component moisture is high (above 1%), we recommend applying an aluminum vapor barrier (e.g., Alujet SE Tape PE) to the wall before installing the substructure.

**IMPORTANT:** Recess the screw head into the substructure so that it does not protrude and impair the adhesive system!

We recommend a maximum distance of 300 mm between the substructure and the panels.

For bonding, we recommend 1K-PUR (single-component polyurethane) or MS polymer adhesive systems. We recommend the adhesive manufacturer INNOTEK with the “Innotec Project System” adhesive system.

Mill out recesses (e.g., sockets, etc.) to be  $\geq 2$  mm larger to counteract expansion.

Milling can be done on site using a hand-held CNC milling machine (e.g., Shaper Origin).

At panel joints, the joints should be formed with  $\geq 2$  mm. The joints can be sealed with a permanently elastic silicone sealant.

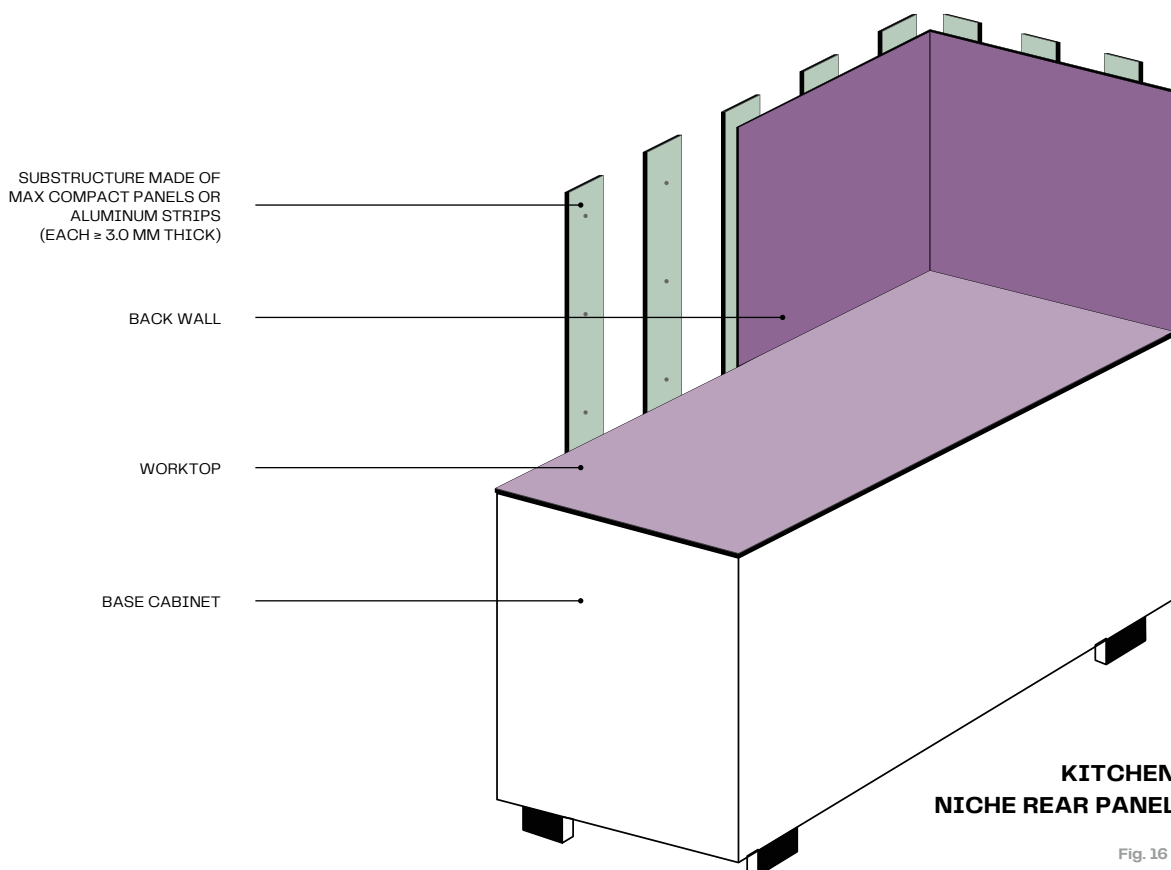

**SIDE VIEW KITCHEN  
NICHE REAR PANEL**

To ensure proper rear ventilation, we recommend placing the substructure 30 mm below the top edge of the worktop.

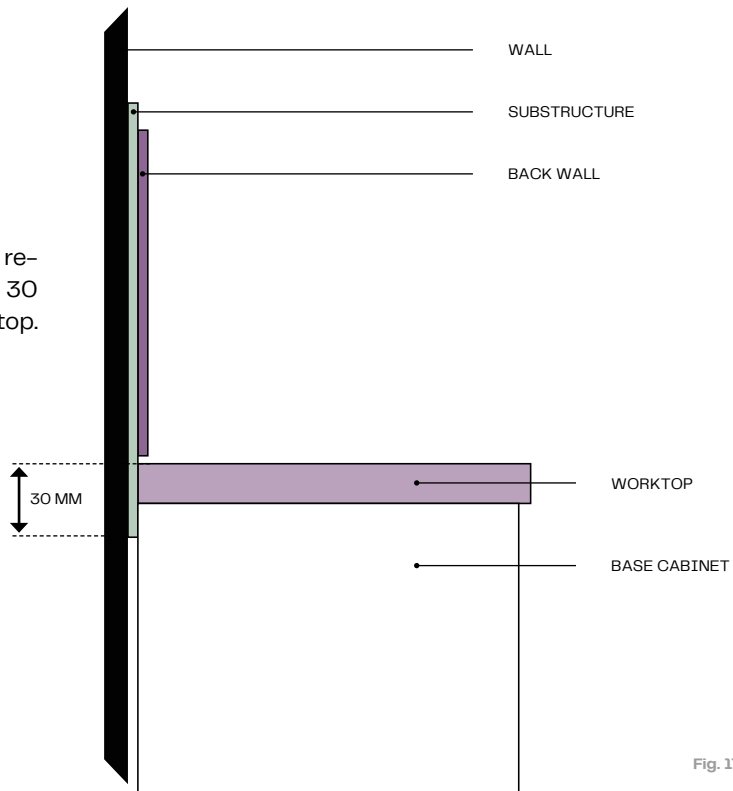

Fig. 17

**CORNER DESIGN  
VIEW FROM ABOVE**

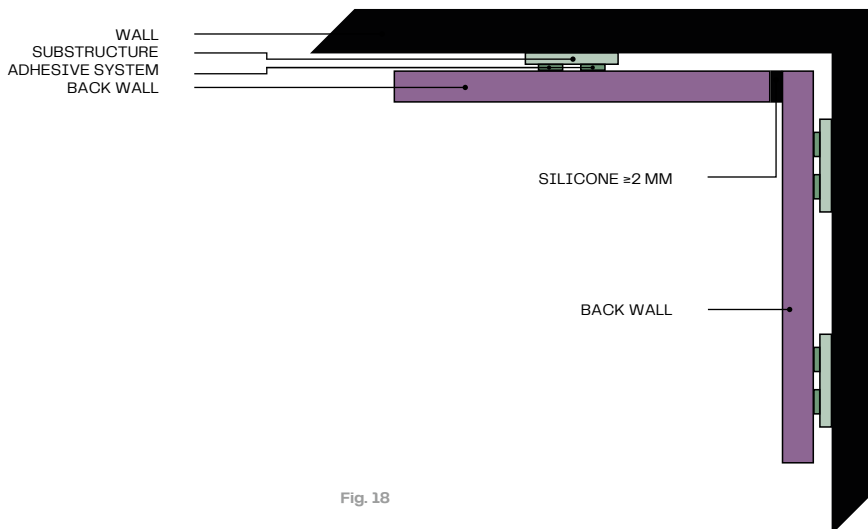

Fig. 18

# The processing of Max Compact worktops

## GENERAL

The surface area of Max Compact worktops contains high-quality melamine resins and is therefore highly resistant. The processing properties of the Max Compact worktops are similar to those for the processing of hardwood. Hard metal cutting tools have been tested and are indispensable when working with Max Compact panels. If a long tool life is required, diamond-tipped (DP) tools should be used. Sharp blades and smooth functioning are both necessary elements to ensure a faultless processing of the material. Breaking-off, splintering and chipping of the decorative side is a result of incorrect handling or unsuitable tools.

Machine tables should be as flat and smooth as possible, so that no chips collect – which can damage the surface area. The same also applies for work surfaces and the controlling of hand-held machines.

## Safety measures

This is simply a list of the recommended personal protective equipment. The standard required protective equipment for the given field of work should be used (work clothes, safety boots, hairnets,...).



### GLOVES

Non-bevelled cut edges are sharp and pose a risk of injury. To protect against the handling of freshly cut Max Compact worktops, gloves of protection category ii with a minimum cut resistance of 2 should be used.

EN 388		Mechanical risks	
		The higher the digit, the better the test result.	
Test resistance	Digit		
Abrasion	4		0 - 4
Bladecut	1		0 - 5
Tear	2		0 - 4
Puncture	1		0 - 4



### EYE PROTECTION

As with the manufacturing of any other wood, tightly-sealed eye protectors must be worn when working with Max Compact.



### DUST PROTECTION

As with the manufacturing of any other wood, the processing of Max Compact worktops can create dust. For sufficient respiratory protection, dust mask filters for e.g. should work.



### HEARING PROTECTION

During the mechanical treatment of Max Compact panels the sound level can rise to above 80 dBA. Please ensure that you have adequate ear protection at all times when working with these materials.

## General processing guidelines

When working with Max Compact worktops the ratio between the number of teeth ( $z$ ), the cutting speed ( $v_c$ ) and the feed rate ( $v_f$ ) must be observed..

	$v_c$	$f_z$
	m/s	mm
Saw	40 – 60	0,02 – 0,1
Mill	30 – 50	0,3 – 0,5
Drill	0,5 – 2,0	0,1 – 0,6

Table 3

### CALCULATION OF CUTTING SPEED

$$v_c = D \cdot \pi \cdot n / 60$$

$v_c$  – cutting speed

$D$  – tool diameter [m]

$n$  – tool rotational speed [min<sup>-1</sup>]

### CALCULATION OF FEED SPEED

$$v_f = f_z \cdot n \cdot z / 1000$$

$v_f$  – feed rate [m/min]

$f_z$  – tooth feed

$n$  – tool rotational speed [min<sup>-1</sup>]

$z$  – number of teeth

### CUTTING MATERIAL

Tools with hard blades (e.g. HW-Leitz) can be used.

In order to extend tool life, the use of DP-tipped tools (DP polycrystalline diamond) is recommended..

### GENERAL ADVICE

If chip removal is not carried out regularly, this can quickly lead to damage of the blade. As a result the required engine power is increased and the tool life will be shortened.

If the shavings are too small they will then scrape and eventually blunt the tool, therefore leading to a short tool life.

For single cuts, it is imperative that the vibration of the panels is prevented using used panels.

Stack height is in compliance with machine capacity.

## Cutting

### VERTICAL PANEL SPLITTING, TABLE AND SLIDING TABLE SAWS WITHOUT SCORING UNIT

For **circular saw blades with a positive rake angle** and saw shaft under the work piece. Due to the positive rake angle, the cutting pressure takes effect using the stable table support.

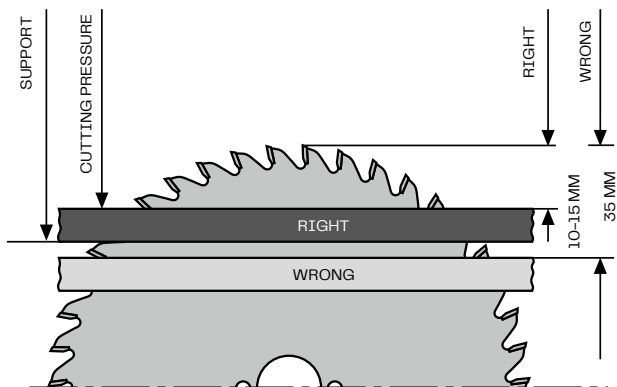

Fig. 19

For **circular saw blades with a negative rake angle** and saw shaft above the work piece. Through the negative rake angle, the cutting pressure takes effect using the stable table support.

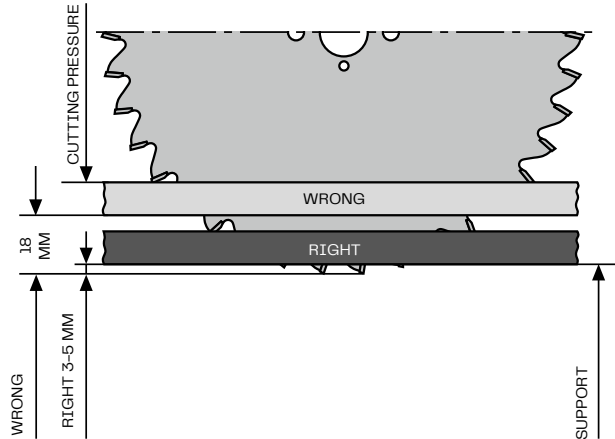

Fig. 20

### Adjustment

- visible side upwards;
- very narrow saw guide;
- smooth alignment of the Max Compact panels on the workbench with the saw blade;
- correct blade protrusion.

Depending on the blade protrusion, the entrance and exit angles and therefore the quality of the cutting edges will change. If the upper cutting edges are unclean, the saw blade will need to be adjusted to a higher level. The saw blade must be adjusted to a lower level for an unclean cut of the underside. This is how the best height adjustment is determined.

### SLIDING TABLE SAWS AND PANEL SPLITTING MACHINES WITH SCORING UNIT AND PRESSURE BEAMS.

#### Scoring circular saw blade:

In order to achieve a good cutting edge quality on the saw exit side, the use of a scoring unit is recommended. The cutting width of the scoring circular saw blade is slightly bigger than that of the main circular saw blade so that the exiting teeth of the main saw no longer touch the cutting edge.

As a secure and smooth circulation of the work pieces can only be guaranteed using a pressure device, divided scoring circular saw blades are used on the table and sliding table machines.

Panel splitting unit with scoring aggregate and pressure device.

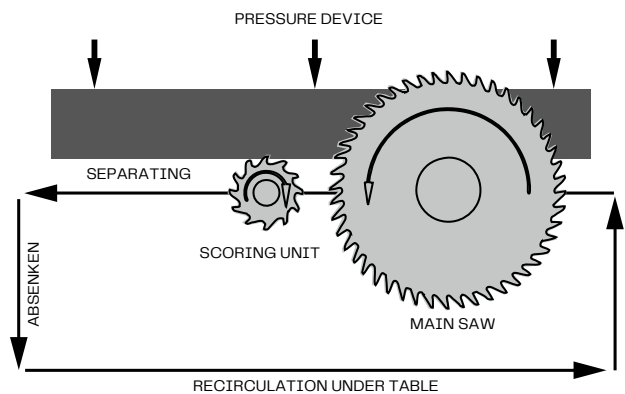

Fig. 21

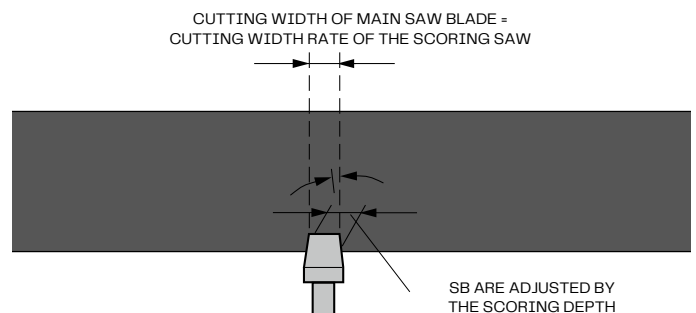

Fig. 22

Operating diagram of the conical scoring circular saw. for the maintenance of tools (always step-by-step), the cutting widths must be aligned with one another.

## TOOTH FORMS

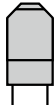
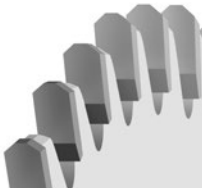

Fig. 23

### TR/TR (Trapezoid tooth/ trapezoid tooth)

Preferred tooth forms for the cutting of hard abrasive laminates.

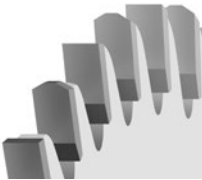

Fig. 24

### FZ/TR (Flat tooth/trapezoid tooth)

Tooth form for the processing of laminates and Compact panels.



Fig. 25

### WZ/FA (Variable tooth with bevel)

An alternative to FZ/TR tooth.

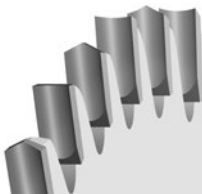

Fig. 26

### HZ/DZ (Concave tooth with bevel)

Tooth forms for excellent and below on machines without scoring units.

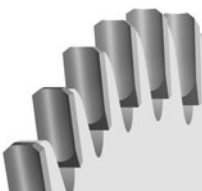

Fig. 27

### HZ/FA (Concave tooth with bevel)

Similar use to hz/dz only with longer machine life without scoring units.

## Cutting with handheld tools

For straight cuts with handheld circular saws, a stop bar or guide rail should be used. Saw blades suitable for hard metal use should be used. The sawing takes place from the panel underside using the following tooth forms:

- WZ/FA for coarse cuttings
- FZ/TR for clean cuts

of Max Compact worktops and panels which are bonded on both sides.

## Milling machines – edge processing

### EDGE PROCESSING BY HAND

For the finishing of edges, files are suitable. The file direction moves from the decorative side to the core. For broken edges, fine files, plane files, sand paper (100–150 grain) or scrapers can successfully be used.

### EDGE PROCESSING WITH HANDHELD MACHINES

To mill bevels electric hand planes with bevel or bevel grooves can be used. Hand routers are used along with hard metal tools for special tasks (e.g. wash basin recess, trax-coupling etc.).

In order to protect the Max Compact panel surface areas, the supporting surface of the hand routers should be covered with for e.g. panel parts, no felt! Milling shavings should be carefully removed.

We recommend hard metal tipped milling cutters, which are also available with indexable inserts. For a better functioning of your tools, heightadjustable milling cutters are preferable. The sharp edges will be broken down afterwards.

### EDGE PROCESSING WITH WITH STATIONARY MACHINES

For milling work on the Max Compact worktops, the optimal ratio of teeth, cutting speed and feed rate should be observed.

If the shavings are too small, the machine will scrape (burn) and therefore blunt quickly, meaning it only has a short service life. On the other hand, if the shavings are too big, the edges will be wavy (strokes) with an unclean finish. High rotational speeds are not the only criterion for good quality edges!

When working with the hand fed machines, only those with the marking ‚MAN‘ or ‚BG-test‘ should be used.

Furthermore, the given machine speed range should neither be exceeded nor fallen short of for reasons of safety. Hand fed machines should only be used when working in the opposite direction.

### FINISHING OF MILLED EDGES

Sand the edge surface and smooth out the sharp edges with sandpaper. When processing edges, hand planes with steel residue can be used. It is also recommended that HSS blades are used. The cutting angle of the blade should be approx. 15°C.

For the processing of Max Compact worktops, milling heads with an HW indexable insert blade or diamond-tipped cutter are suitable.

The black panel edges can be given a uniform color by wiping them with silicone-free oil.

### EXAMPLES OF POSSIBLE EDGES AND CORNERS

For Max Compact worktops no edge protection is necessary.

For visible edges, there are a wide variety of structural possibilities.

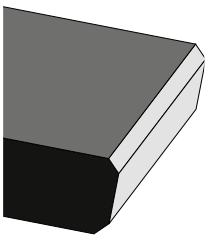

STANDARD BEVEL /  
TYP B  
Fig. 28

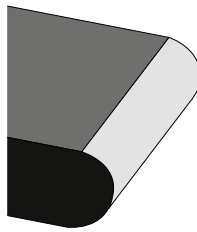

MILLING CONTOUR 3 /  
TYP G  
Fig. 32

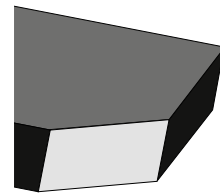

BEVELLED CORNER / TYP L  
Fig. 35

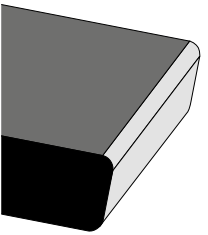

ROUNDED EDGES ON  
BOTH SIDES / TYP D  
Fig. 29

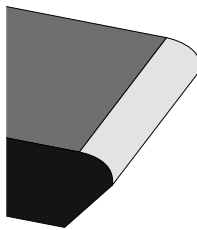

MILLING CONTOUR 4 /  
TYP H  
Fig. 33

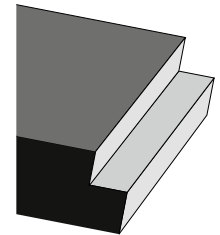

MILLING NOTCH / TYP M  
Fig. 36

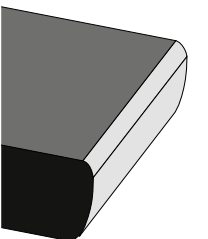

MILLING CONTOUR 1 /  
TYP E  
Fig. 30

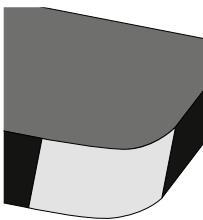

ROUNDED CORNER /  
TYP K  
Fig. 34

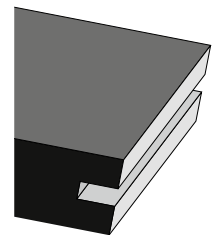

MILLING GROOVE /  
TYP N  
Fig. 37

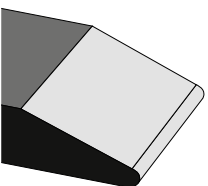

MILLING CONTOUR 2 /  
TYP F  
Fig. 31

#### Note:

The current data sheet on processing possibilities of Fundermax can be found at: [www.fundermax.at](http://www.fundermax.at) under ‚Downloads‘ – ‚ordering facilities‘.

## Joining

### TO JOIN IN CLIMB OR CONVENTIONAL (E.G. VARIABLE MILLING)

#### The following machines are used:

Spindle moulding machine, edge processing machines and Double-end profiler (hand fed in conventional motion only)

#### INFORMATION ON MILLING EQUIPMENT:

Milling head with reversible blades, divided cuts and reciprocal shaft angle for a splinter-free joining edge. Machine creates cylindrical finish for large material thickness (approx. 0.10 mm). For completely straight cutting surface, the Diamaster joint cutter WF 499-2 is recommended.

You will find detailed information at company Leitz.

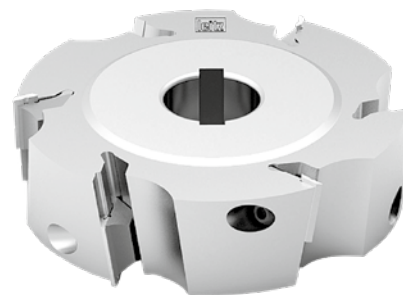

LEITZ JOINT MILLING HEAD-  
INDEXABLE INSERT MODEL

Fig. 38

### FOR SOUNDPROOF JOINTS ON NARROW WORK PIECE SURFACES CLIMB AND CONVENTIONAL (VARIABLE MILLING)

#### The following machines are used:

Edge processing machines, copy milling machines etc.

#### INFORMATION ON MILLING EQUIPMENT:

Composite tool with mutual shaft angle for a splinter-free joining edge and straight narrow surface. Noise reduction up to 5dBA and highly efficient collection of shavings (over 95%).



LEITZ DIAMASTER JOINT CUTTER DP-TIPPED

Fig. 39

## Routers

For processing using router machines and machining centres, solid hard metal

twist or diamond-tipped router drills are best suited. Work pieces must be well clamped and if necessary, additional mechanical tensioners can be used to support the suction cup. It is also recommended that shrink-fit thermoGrip jaw chucks are used instead of collect chucks as they offer the highest stability and stiffness of all known tensioning systems for shaft tools.

**A satisfactory processing result can only be achieved if there is sufficient stiffness in the machine. 'Light' radial machines are only of limited suitability. Ideal: Stiff portal machines.**



LEITZ SPIRAL ROUTER MACHINE  
MARATHON FINISH

Fig. 40

### FORMAT, GROOVE AND FINISH MILLING

For high requirements of cut quality – Z3 model for high feed rates.

The following machines are used: Router machines with/without cnc control, machining centres, special milling machines with milling spindles for use with shaft work tools.

#### INFORMATION ON MILLING EQUIPMENT:

Marathon laminate for enhanced service life and reduced gradient for the formation of built-up edges. Usually used for roughing end mills, cutting allowances of approx. 1–2 mm mirror grinding on the rake surface for processing.

### ROUTER CUTTERS FOR FORMATTING, AND GROOVING WITH LEDGE FREE CUT

The following machines are used: Router machines with CNC control, machining centres, special milling machines with milling spindles for use with shaft work tools.

#### INFORMATION ON MILLING EQUIPMENT:

Negative rake angle of the blade for chip-free finish when grooving and for support of the work piece tensioning for small mill parts. Can be re-sharpened 5 to 8 times with normal blunting. Short, stable cutting blade therefore particularly suited for grooves and shaping of abrasive and hard-to-cut materials.



LEITZ ROUTER MACHINE DIAMASTER PLUS

Fig. 41

## CNC processing

The following points should be taken into account when working with Max Compact on CNC devices.

### FIXING PANELS ON A MACHINE TABLE

There are basically two ways to fix or tension Max Compact worktops on machine tables depending on the type of processing to be performed: When milling to size or edging both sides of a panel section, it is recommended to fix the panel in place using suction cups at specific points. Notice: The proper distance between the suction cups must be observed!

When milling to size, edging one side, making perforations or free-form milling a panel section, it is recommended to fix the panel in place using MDF protective boards (protective boards can be used several times).

The following applies for both options: It must be ensured that the suction cups provide sufficient holding power for the work to be performed. If the suction cups do not provide sufficient fixing or tensioning power, the suction cup seals (e.g. the sealing rings) must be checked.

### SPACING OF THE SUCTION CUPS

As a rule, the material being processed should not be subjected to any vibrations. Therefore, it is important that the suction cups are placed at an appropriate distance from the freely protruding panel edge based on the thickness of the panel. The following applies: the more suction cups and the smaller the distance from the free protruding edge of the panel, the cleaner the milling pattern. As a rule of thumb, suction cups should be placed in the area to be processed in a grid of max. 300 mm with a maximum distance from the free protruding edge of the panel of no more than 30 mm. The best results are achieved by using an MDF protective board (e.g. 19 mm thick), as this enables a full-surface fixing of the Max Compact panel on the machine table with suction cups.

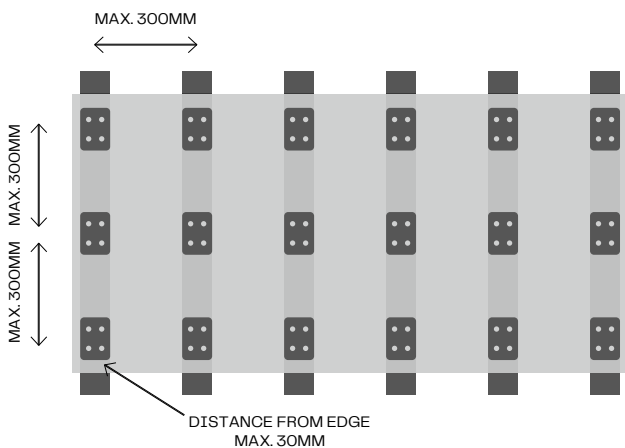

SPACING OF THE SUCTION CUPS

Fig. 42

### CHOICE OF MACHINING TOOL

Generally speaking, Max Compact worktops can be machined with solid carbide (VHM) and diamond (PCD) milling tools. The basic prerequisites for a clean milling pattern and a long service life are vibration-free tool holders and spindles. NOTE: The ball bearings must be properly maintained!

Diamond tools have proven particularly suitable for processing a large amount of panels or a high number of running meters. Smooth-running milling cutters with a shank diameter of min. 10 mm in combination with straight continuous DIA cutting edges (2+1 knife) are especially suitable for format milling.

It is essential that the feed rate and the cutting speed be adjusted for the specific job and cutter based on the material being processed. We recommend always consulting the tool supplier first.

### CLAMPING SYSTEM OF THE MILLING TOOL

It is essential that the spindle be centered in the chuck to ensure the smooth running of the milling cutter. The more centered and play-free the milling cutter can be clamped in place, the better the result. Most machines are equipped with common tool holders such as collets, hydro grips or shrink chucks.

For the professional CNC machining of larger jobs, a hydro grip tool holder or shrink chuck is recommended as they guarantee the best tool clamping. It is important to ensure the proper maintenance of all moving parts such as plain or ball bearings in order to avoid vibrations in every direction!

### EXTRACTION

The extraction or the extraction power must be adjusted accordingly for the material being processed to ensure that all the shavings are optimally removed.

If the extraction is not strong enough, there is a risk of heat development. This is due to shavings that remain between the cutter and the panel edge. High friction occurs at this point because the cutter can not eject the material any further. This can lead to burn marks on the panel edge.

### CNC MACHINING BY FUNDERMAX

Fundermax has their own machining center – Compact Elements. We are happy to machine Max Compact, Max Compact Exterior, Max HPL and m.look panels to your specifications. Simply contact our customer service center for more information.

## Edges and grooves

Grooved edges on Max Compact worktops should always be bevelled, not sharp-edged! This spares the corners of the machine (indexable inserts) and prevents a notch effect. The service life can often decrease dramatically depending on the height adjustment, the machine type and form, the cutting requirements and support material. For high volume production, the use of diamond-tipped machines should be considered.

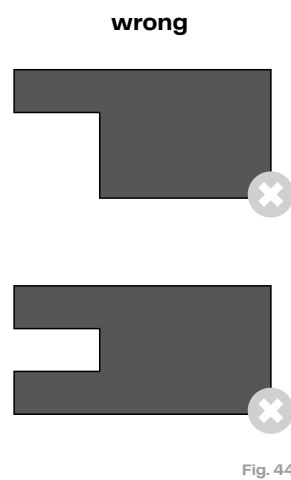
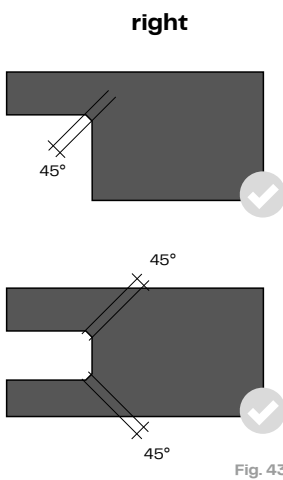

## Inner notches and cut-outs

With inner notches and milling grooves, the corners are consistently rounded off. The inner radius should be kept as large as possible (minimum radius 5 mm). For inner notches and milling grooves over 250 mm sidelength, the radius must be gradually increased in line with the side-length.

Inner notches can be directly formed using the milling cutter or they can be pre-drilled with a corresponding radius, before the cut from drill hole to drill hole is milled. Sharp-edged corners are weak and lead to the formation of cracks due to tension.

Moreover, all edges must be ripplefree. If, sharp-edged corners are required for constructive reasons, this can only be achieved through a combination of compact panel blanks. The suitable cutting, milling and drilling machines for the production of inner notches and milling grooves are described in the previous sections.

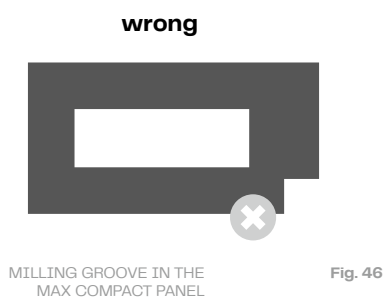

### MACHINE SUPPLIERS

Leitz GmbH & Co. KG  
Leitzstraße 80  
A-4752 Riedau  
Tel: +43 (0)7764/8200 – 0  
Fax: +43 (0)7764/8200 – 111  
Email: office.riedau@rie.leitz.org  
www.leitz.org

OERTLI-LEUCO Werkzeuge GmbH  
Industriepark Runa  
A-6800 Feldkirch  
Tel: +43 (0)5522/75787-0  
Fax: +43 (0)5522/75787-3  
Email: info@oertli.at  
www.oertli.at

Ledermann GmbH & Co. KG  
Willi-Ledermann-Straße 1  
D-72160 Horb am Neckar  
Tel: +49 (0)7451/93 – 0  
Fax: +49 (0)7451/93 – 270  
Email: info@leuco.com  
www.leuco.com

## Drilling

Solid hard metal twist or dowel drills are used for drilling. In machining centres, the use of the main spindle instead of the drilling beams for a rpm of 2000 – 4000 min<sup>-1</sup> and a feed rate of 1.5 – 3 m/min, is recommended. The exit speed of the drill must be carefully selected so that the melamine surfaces of the Compact panels are not damaged.

Shortly before the drill exits the work piece in full diameter, the feed rate must be reduced by 50%. When drilling through-holes, the counter-pressure should be built up using hardwood or equivalent material to prevent break-offs of the melamine surface.

### For the screwing of blind holes perpendicular to the panel levels, please ensure:

- Tap drill diameter (D) = screw diameter minus approx. 1 screw channel depth.
- Drilling depth (a) = panel thickness minus 2 mm after deducting all tolerances.
- Screw-in depth = drilling depth minus 1 mm

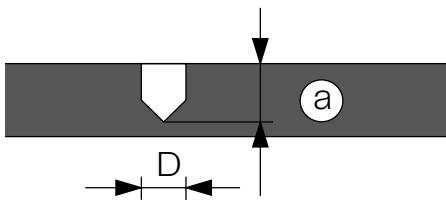

Fig. 47

### For screw fittings parallel to the panel level, please ensure:

- The residual thickness (b) of the Max Compact panel must be at least 3 mm after deducting all tolerances.
- The hole diameter of the drillings parallel to the panel surface must be selected in such a way to avoid any splitting of the compact panels when tightening the screws.
- For screw fittings parallel to the panel surface, metal sheet and chip boardscrews are suitable.
- In order to ensure respective stability, a minimum depth of engagement of 25 mm is necessary.

It is imperative that tests to establish the correct drill diameter are carried out.



Fig. 48

For the drilling of Compact panels, drills for plastics are best suited. This means twist drills with a point angle of  $\leq 90^\circ$ . They have a large gradient and chip space.

The sharp drill bits mean that these drills are also very suitable for the drilling of through-holes as they cut cleanly through the underside of the material.

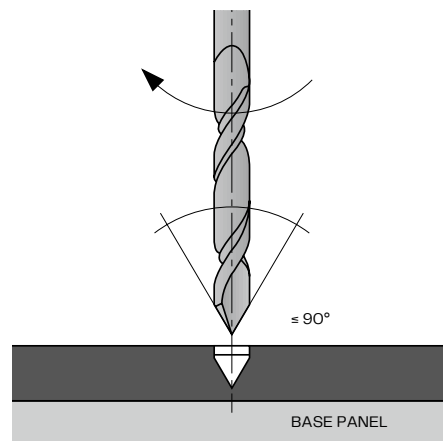

Fig. 49

### UNIVERSAL DRILLING OF BLIND AND THROUGH-HOLES

#### The following machines are used:

Point-to-Point drilling machines, through feed drilling machines, CNC machining centres, box column drill, inlet-fitting drilling machine, drilling units, hand drills.

#### INFORMATION ON THE DRILLS

Flat roof drill bits. Shaft diameter identical to blade diameter. Adaptable for shaft-D 10 mm with reducing bush TB 110-0 or Pm 320-0-25.



LEITZ-DRILL HW-SOLID, Z2

Fig. 50

### TIERED HINGE DRILLING

Particularly for screw-in hinges in door manufacturing.

#### The following machines are used:

CNC machining centres, drilling units, hand drills.

#### INFORMATION ON THE DRILL:

Model HW Z 2, 2-tiered. 1tier with roof drill bit.

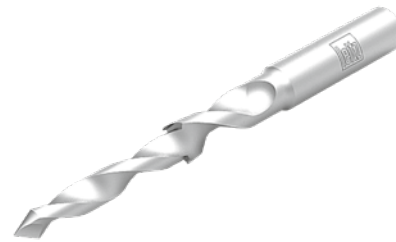

LEITZ-DRILL SHAFT 10 MM

Fig. 51

### DRILLING OF BLIND HOLES

In particular dowel holes in cabinetry. Particularly suitable for the tear-free drilling of blind holes in visible quality as well as the processing of panel materials. Not suitable for through-holes!

#### The following machines are used:

Point-to-Point drilling machines, through feed drilling machines, inlet fitting drilling machines, drilling units, CNC machining centres.

#### INFORMATION ON THE DRILL:

Roughing geometry with extremely clean cut. Model HW-solid with highly wear-resistant HW varieties. High stability and long service life. Polished chip space for minimal friction and feed force.

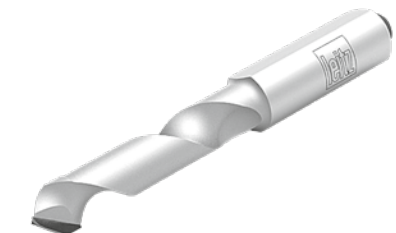

LEITZ-DRILL SHAFT 10 MM

Fig. 52

Pre-punching ensures better control for hand drilling.

Diamond-tipped drills are not suitable for compact panels.

## Cleaning recommendations

Please start the cleaning procedure for unknown stains with basic cleaning, cleaning procedure A to G in order to perform the desired success. To prevent streaking you have to perform a final cleaning. Please observe the general precautions for Aptico in the Technik Max HPL & Aptico brochure.

### **BASIC CLEANING**

Clean the surface just with pure hot water and use a soft sponge – DO NOT scrub (do not use the abrasive „green“ side of the sponge), use a soft cloth or a soft brush (e.g. nylon brush).

### **CLEANING PROCEDURE A**

Same as basic cleaning, in addition use common household cleaners without abrasives e.g. Dish detergent (Palmolive, Fairy), window cleaner (Ajax, Frosch).

### **CLEANING PROCEDURE B**

If the contamination is not removable with the cleaning procedure A, you can use a solution of soft soap – water (1:3). Depending on the degree of pollution leave it on the surface for a couple of minutes..

### **CLEANING PROCEDURE C**

Same as basic cleaning, but you may additionally use organic solvents (acetone, spirit, nitro thinner, turpentine). For heavier soiling, remove the dirt mechanically—however, this must not be done on high-gloss or deep-matt surfaces.

**Caution:** avoid scratching, use plastic or wooden spatula.

### **CLEANING PROCEDURE D**

Same as basic cleaning, but you may additionally use commercially available disinfectants. Steam cleaning is possible. Take care of the supporting material (e.g. wood beams, wall paneling, insulation, ..), to avoid wetting.

### **CLEANING PROCEDURE E**

Remove immediately! If necessary, perform cleaning

procedure c and final cleaning procedure.

### **CLEANING PROCEDURE F**

Rub off the surface with a soft cloth or a soft sponge dry. If contaminants cannot be removed, use silicone remover (e.g. Molto).

### **CLEANING PROCEDURE G**

For persistent limescale acidic cleaning agents may be used (for example, 10% acetic acid or citric acid).

### **FINAL CLEANING**

Detergents have to be removed with water completely to avoid streaking. Finally clean with hot water and rub off the surface with an absorbent cloth or paper towel (kitchen roll).

### **When cleaning with solvent:**

Observe the accident prevention regulations!  
Open windows! No open flame!

TYPE OF STAIN	CLEANING METHOD	TYPE OF STAIN	CLEANING METHOD
Adhesives	C	Marker pen	C
Ballpoint pen	C	Pencil	A
Blood	D	Rust	G
Chalk	A	Sealant (such as silicone)	F
Coffee	A	Shoe polish	C
Dust	A	Soap residue	A
Emulsion paints	C	Stamp ink	C
Feces	D	Tar (cigarettes)	C
Felt-tip pen	C	Tea	A
Fingerprints	A	Urea glue	E
Floor wax	B	Urine	D
Fruit juices	A	Water marks	G
Grease, oil	A, B, C	Water-soluble adhesives	A
Greasy stains	A	Water-soluble paints	A
Hybrid adhesive	E	Wax crayons	C
Lime	G	Wax polish	C
Lipstick	C	Wax residue	C

Table 4

### FINAL CLEANING

Remove cleaning agents completely with plenty of water to prevent streaking. Rinse with clean hot water and dry the surface with an absorbent cloth or paper towel.

**Fundermax Deutschland GmbH**

Mundenheimer Weg 2  
D-67117 Limburghof  
infogermany@fundermax.biz  
www.fundermax.com

**Fundermax France S.a.r.l.**

29 Rue Maurice Flandin  
F-69003 Lyon  
accueil@fundermax.biz  
www.fundermax.com

**Fundermax India Pvt. Ltd.**

Sy. No. 7, Honnenahalli, Doddballapur Road,  
IND-Yelahanka Hobli, Bangalore - 560064  
officeindia@fundermax.biz  
www.fundermax.in

**Fundermax Italia s.r.l.**

Viale Venezia 22  
I-33052 Cervignano del Friuli  
infoitaly@fundermax.biz  
www.fundermax.com

**Fundermax North America, Inc.**

9800 Twin Lakes Parkway, Suite B,  
US-Charlotte, North Carolina 28269  
contactfna@fundermax.biz  
www.fundermax.us

**Fundermax Polska Sp. z o.o.**

ul. Rybitwy 12  
PL-30 722 Kraków  
T: +48 (0)12 65 34 528  
infopoland@fundermax.biz

**Fundermax Swiss AG**

Industriestrasse 38  
CH-5314 Kleindöttingen  
T: +41 (0)56 268 83 11  
infoswiss@fundermax.biz  
www.fundermax.com

**Fundermax GmbH**

**Klagenfurter Straße 87-89, A-9300 St. Veit/Glan**

**T: +43 (0)5 9494-0, F: +43 (0)5 9494-4200**

**office@fundermax.at**

**www.fundermax.com**

**Imprint:**  
Fundermax GmbH, 9300 St. Veit/Glan, Austria  
Producer: Print Alliance HAV Produktions GmbH, 2540 Bad Vöslau, Austria